

Application Note

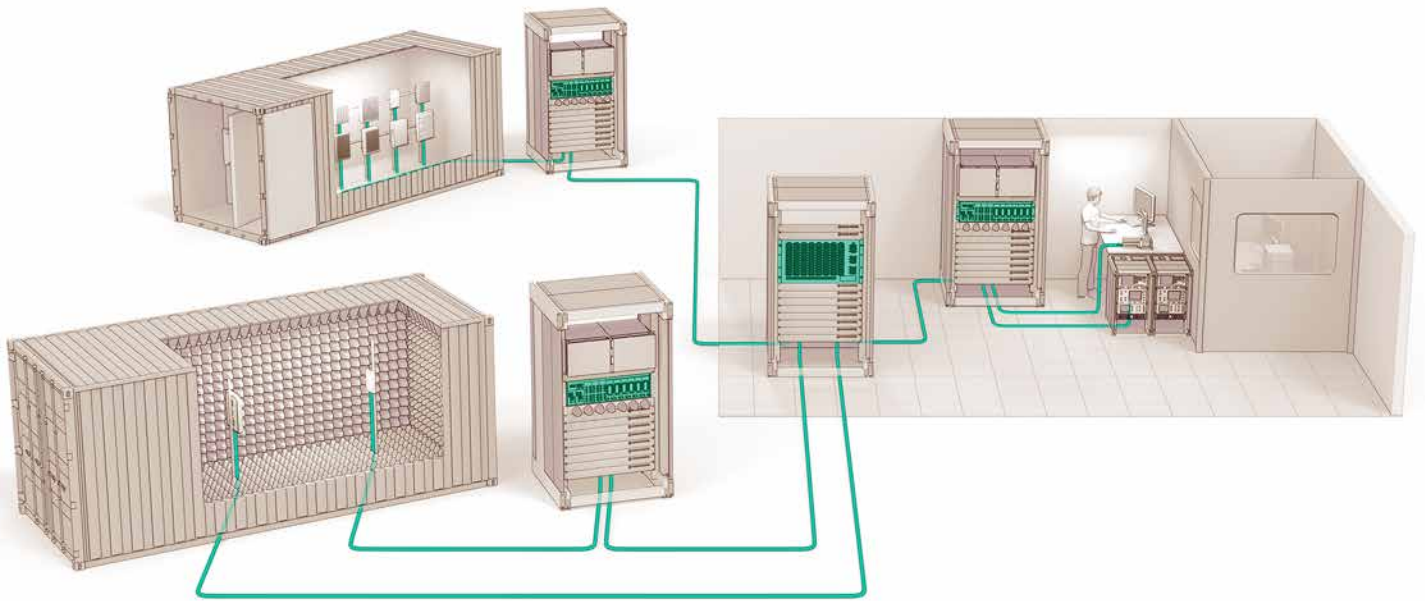

Lab Automation for Carriers

Introduction

Carriers are under intense pressure to rapidly test and deliver enhanced network services, validate new equipment, and even networks as a whole. They also need to be able to reproduce, diagnose and resolve customer issues quickly. All this with the additional challenge of having to test both radio frequency and fiber optic technologies. This drives the need to get even more out of their network test lab resources and effectively combine the testing of the two technologies in the same lab.

Key Features / Benefits

- End-to-end automation solution for carriers' labs
 - 3-4 times faster testing
 - Technology agnostic
 - Maximization of equipment usage
 - RF over Fiber solution
-

Step away from manual testing and move toward an automated lab landscape

In today's rapidly evolving business climate, the longer it takes to certify new gear and new services by relying on manual lab operations, the further away the organization gets from increasing revenue and remaining competitive. In place of traditional interconnected coaxial and manually controlled labs, the integration of fiber connectivity and optical circuit switching provides an automated, transparent, user-configurable fiber layer that is fully independent of test traffic formats or bit rates. This allows labs to be reconfigured in seconds rather than hours

or days, thereby allowing customers to meet challenging test cycle turnaround times, increasing efficiency and reliability.

Moreover, with automation, labs can share expensive equipment and reconfigure tests remotely and immediately. Using readily available tools, resources can be securely shared between labs dedicated to different parts of the network without conflict. This also enables 'follow the sun' access to lab resources with 24-hour global access to shared test equipment.

Carriers challenges in "live" networks

- Extensive test cases involving regression, features, interoperability and extensions such as Common Protocol Radio Interface (CPRI)
- Continuous software updates of network elements
- Fast deployment of security-related software in network elements
- Complex regression testing due to coexistence of numerous technologies, frequencies and access modes
- Software malfunctions "bugs" in current software caused by new software releases



The HUBER+SUHNER solution

- End-to-end lab automation solution.
- High reproduceability, traceability, reporting and increased efficiency.
- Future ready including new 5G bands and beyond.
- Optical circuit switch which is protocol and data rate agnostic.
- Faster time to market.

Examples of typical carriers' test procedures

Regression

Regression testing is needed to verify that new software releases do not impact the existing functionality of the network.

The new releases may be due to a change in the requirements like adding new functionality, patching for issues such as bugs or security vulnerabilities.

The software updates have to be done constantly and in an exponentially increasing complexity due to the use in the network of

multiple-vendors' equipment, multiple spectrum bands and different technologies.

Regression testing can include thousands of individual software tests that must be run in cascaded sequences, therefore using an end to end automated solution can drastically reduce the time for test set-up and for actual testing. This allows carriers to introduce new software releases faster than before and in a simple and reliable manner.

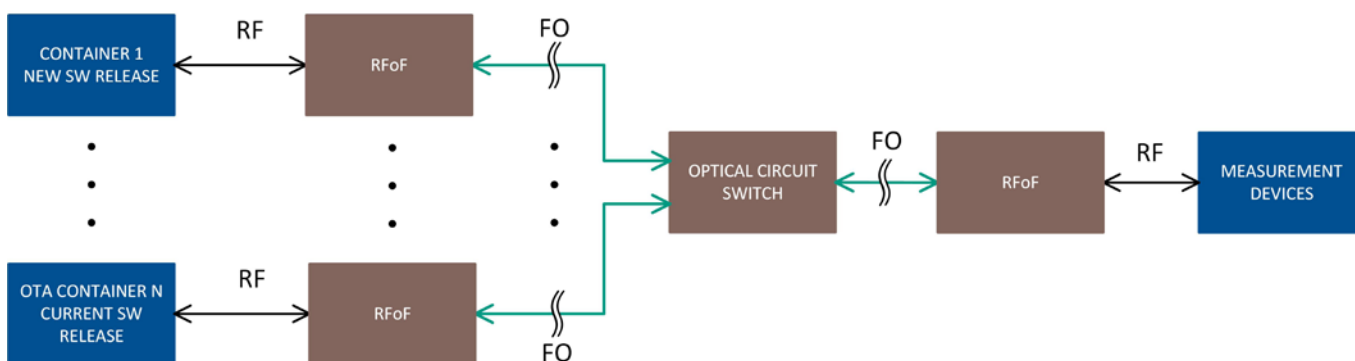

Feature

There is an enormous effort from the carriers' side to improve the network performance and to enhance user experience. At the same time the new features (i.e. extremely high throughput, ultra-low latency and network slicing) which are needed to improve the network functionality are increasing in complexity as well as in the pace at which they are being released.

To overcome this challenging environment, carriers can implement lab automated scenarios that allow agile and efficient feature testing. Feature testing is needed to verify that the new functionalities work on an end-to-end basis before being introduced into the live network.

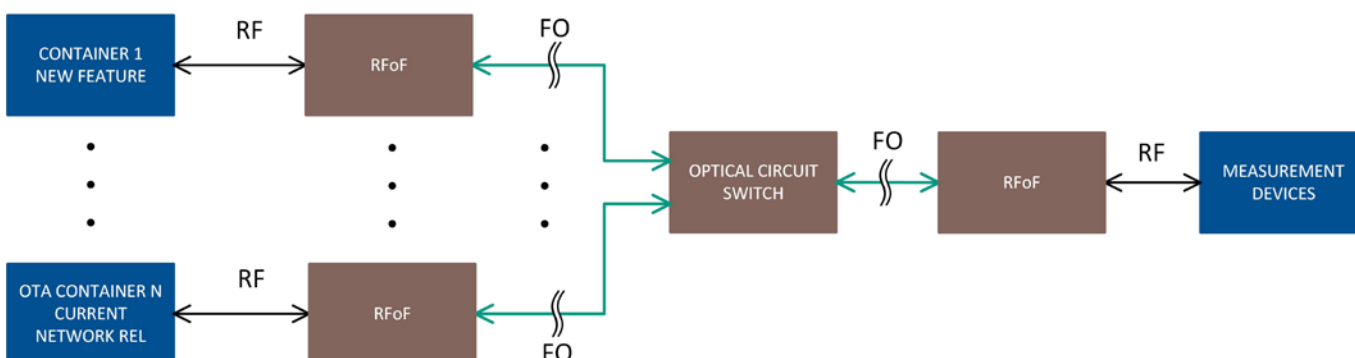

Interoperability

In a Mobile Network various Original Equipment Manufacturers' (OEMs) equipment as well as different technologies (i.e. 4G LTE and 5G NR) typically co-exist. Moreover the introduction of new network architectures like Open RAN, disaggregated and centralized networks, challenges carriers by requiring additional testing of interoperability to ensure that all network elements and interfaces function according to predefined standards and can coexist.

To overcome this complexity, interoperability testing can be done with the help of a lab automation solution that simplifies the testing of virtual RANs, open standard software and hardware.

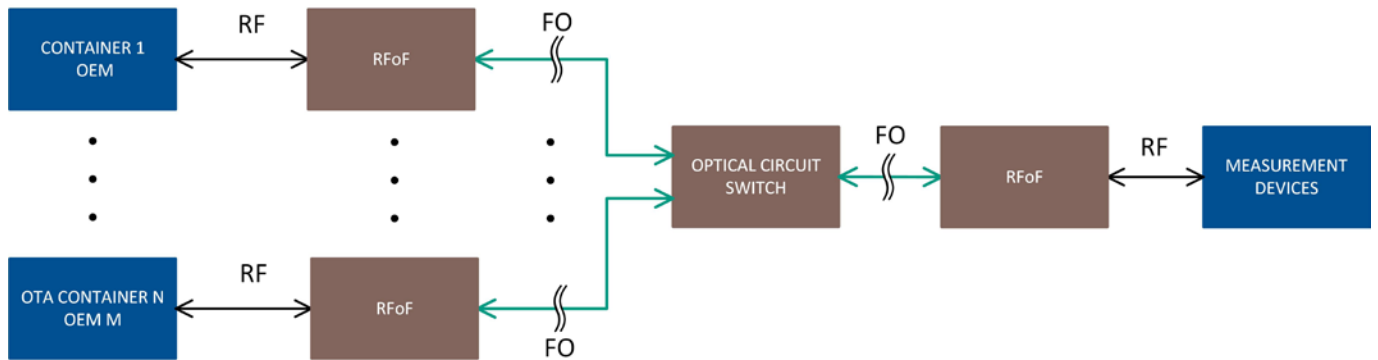

CPRI extension

CPRI extension testing verifies the digitized radio data and control information between the Base Band Unit (BBU) and the Remote Radio Unit (RRU) or Active Antenna Unit (AAU); or between the Radio Unit (RU) and the Decentralized Unit (DU), referred as the front-haul interface.

with fiber optic connectivity and can be easily, reliably and rapidly tested within an automated lab environment.

As these interfaces are digital, they do not require RF over Fiber components but can be fully measured

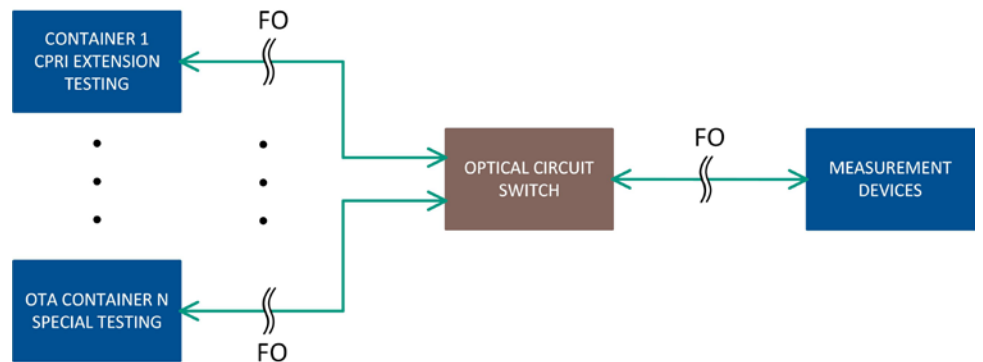

Transport & Core Labs

Transport and core labs must thoroughly test new equipment and services before deploying in the infrastructure to verify reliability and performance. These test labs are also used to simulate customer network environments so that issues can be identified and resolved quickly. In trans-

port labs the transport equipment which could be muxponders, DWDM terminals, edge routers, amplifiers, line cards, to mention a few, will be integrated for testing. The typical use cases are optical component testing, optical module testing and characterization of optical devices.

Technology considerations

Coaxial vs. Fiber

With an end-to-end fiber network (RFoF and optical circuit switch), organizations can now deploy highly secure and flexible solutions with capabilities that are not possible with traditional coaxial based systems taking full advantage of the benefits of fiber optics end-to-end, including:

- High level of security from DUT to test equipment
- Redundant paths are easy to configure and inexpensive
- Future proof: any frequency, any data rate, any modulation format – today and in the future end-to-end
- Extremely light weight, compact form factor and much easier to deploy
- Improved performance, readiness, and resilience at lower overall costs.

Radio Frequency vs. Light

Radio Frequency (RF) signals have been distributed over coaxial cables for decades, but for today labs' complexity, it can be limiting, expensive, and unreliable. To overcome these limitations, RF and test systems engineers are turning more and more to RF distribution over optical fiber (RFoF).

In RFoF systems, electro-optical (E/O) converters are used to convert RF to optical at the signal source, then transmit it along a length of single-mode optical fiber to the destination where optical-electrical (O/E) converters convert the signal back to RF.

Light main advantages include:

- Extremely low transmission losses
- Immunity to electromagnetic signal interference

Optical circuit switch vs. MEMS-based optical switch

The analog nature of RF requires a switching infrastructure that does not degrade the RF signal. This requires a high-performance optical circuit switch with ultra-stable operation as well as low back reflections and low insertion loss.

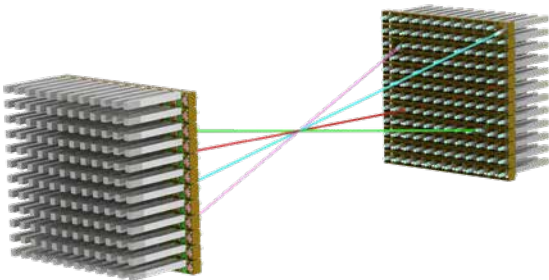

The patented POLATIS DirectLight™ high-performance switching technology from HUBER+SUHNER, minimizes impairments to RF signals traversing the switch connections.

DirectLight high-performance switching technology uses integrated position sensors to directly align optical collimators to make and hold connections which eliminates the need for signal dithering that can degrade RF signals. DirectLight enables the creation of dark fiber connections, meaning test paths can be pre-provisioned if needed.

This is a critical advantage over MEMS-based optical switching technologies that use mirror dithering as part of the alignment process, to make and hold connections, which adds unwanted signal modulation. In RF systems this MEMS-based excess modulation is mixed directly with the RF signal, adding to the signal noise floor and degrading the RF performance.

Lab automation architecture

The lab automation solution interconnects Device under Test (DUT) with measurement equipment to perform automated RAN and core/transport testing.

The interconnection consists of:

- 1** RFoF module
- 2** 19" CUBOrack
- 3** Optical Circuit Switch
- 4** Accessories

Additional features such as:

- 5** Network Management System (NMS)
- 6** API for customer specific software developments

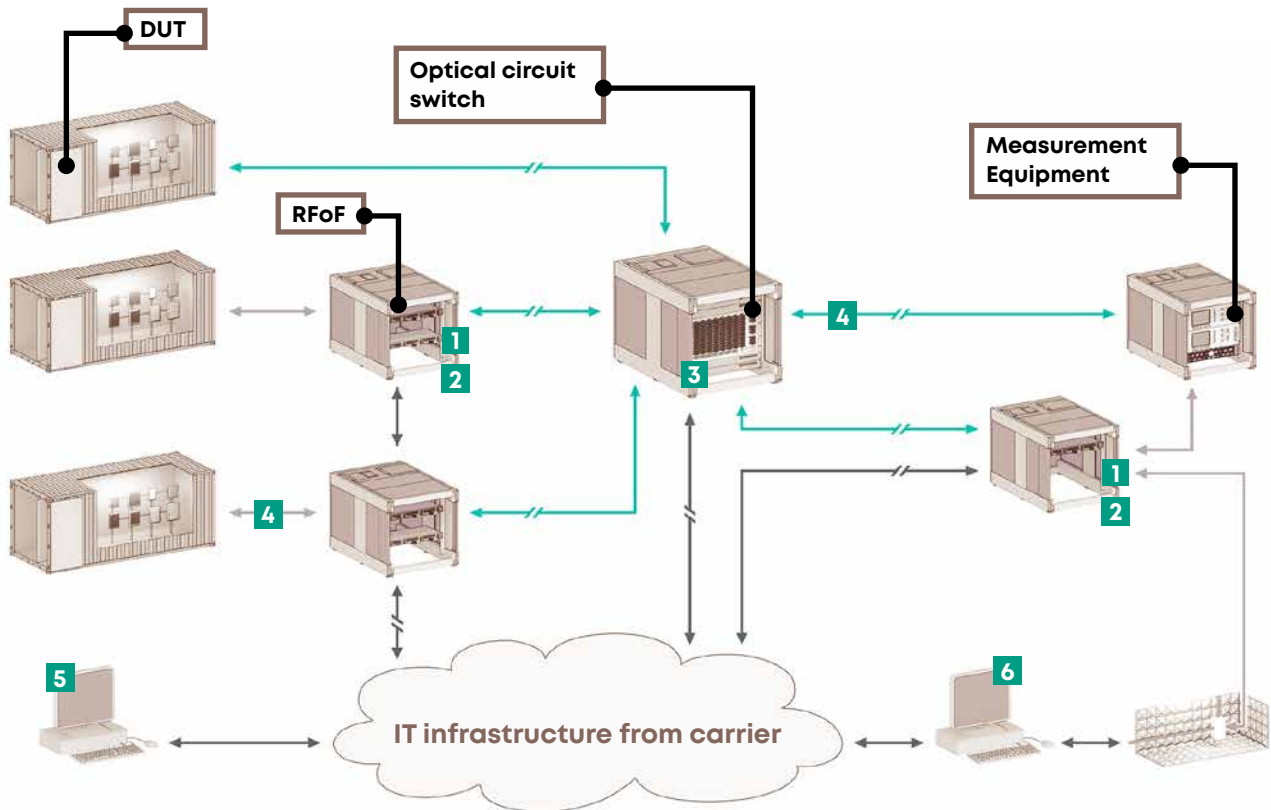

Item	Description	Items	Part Number
1	RFoF Bidirectional RF and FO Transceiver (2 channels) Duplexer (4 channels)	RS-RFoF08-13T2R2W RS-RFoF08-15T2R2W RS-RFoF08-DUP	85252241 85252243 85225216
2	19" CUBOrack (for 9 RFoF modules) Power Supply Unit (PSU) AC Variant EU / US DC Variant Management Module	RS-CH3U-0 (empty chassis) RS-AC460-1 EU / RS-AC460-1 US RS-DC460-1 RS-MO-2	85095578 85238554 / 85238555 85274092 85264606
3	Optical Circuit Switch (Custom configurable - any-to-any port connections)	32 x CC 48 x CC 64 x CC 192 x CC 256 x CC 384 x CC	I-OST-32xCC-LA1-HMHNS I-OST-48xCC-LA1-HMHNS I-OST-64xCC-LA1-HMHNS I-OST-192xCC-LA1-HMWNS I-OST-256xCC-LA1-HMWNS I-OST-384xCC-LA1-HMWNS
4	Accessories	RF Jumpers FO assemblies and FO management systems	Harsh environment cabling for the mobile network catalog Structured cabling for data centers catalog

5 and **6** are additional features (interfaces) provided through **1**, **2** and **3**

(1) RF over Fiber (RToF) modules

The RToF modules have diverse configurations in order to fulfill the different interconnection requirements from the carriers. The RToF module is available as:

Transmitter (TX) and Receiver (RX) as separate modules

This means for an RF signal connection, a Transmitter (TX) is used to convert the RF signal into an optical signal prior to transportation. While on the Receiver (RX) side the optical signal is converted to RF through the RX module. The optical link operates at either 1310nm or 1550nm.

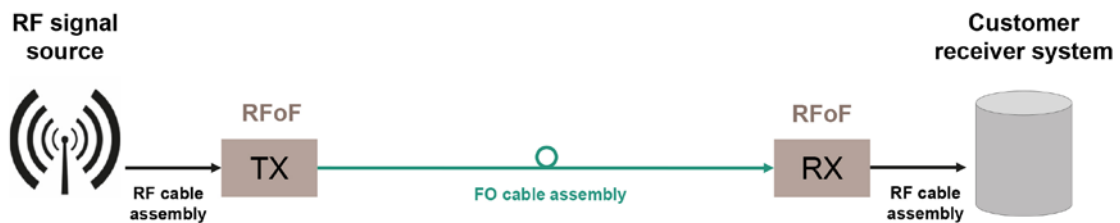

Transceiver module (TRM)

This module incorporates both Transmitter (TX) and Receiver (RX) within the same electronic card reducing by half the amount of RToF modules needed for a bi-directional link. Two fibers transport two TX signals respectively.

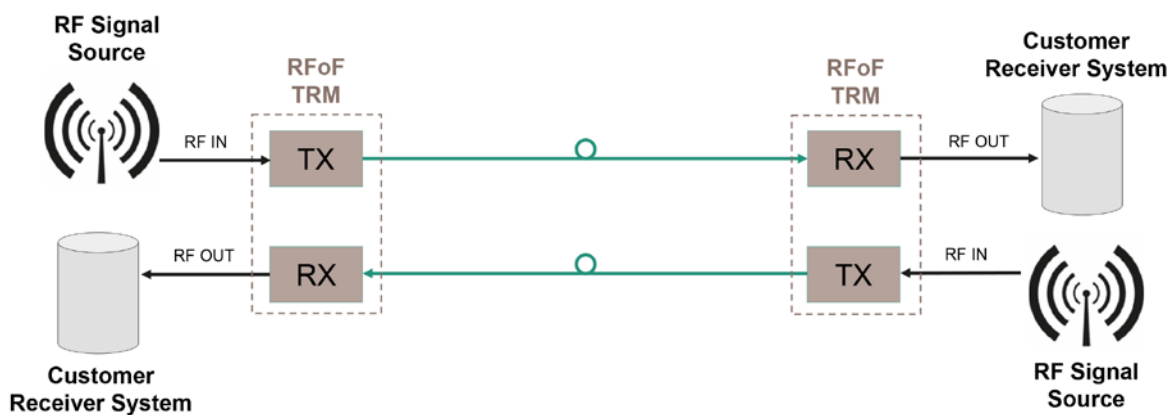

Transceiver module with bi-directional RF functionality

This module incorporates both Transmitter (TX) and Receiver (RX) within the same electronic card and an RF duplexer module to separate transmission and reception signals. This type of module support Time Division Duplex (TDD) scenarios where the RF connection to the customer system is done through a single connection which carries uplink and downlink traffic together. Two fibers transport the TX and RX signals respectively.

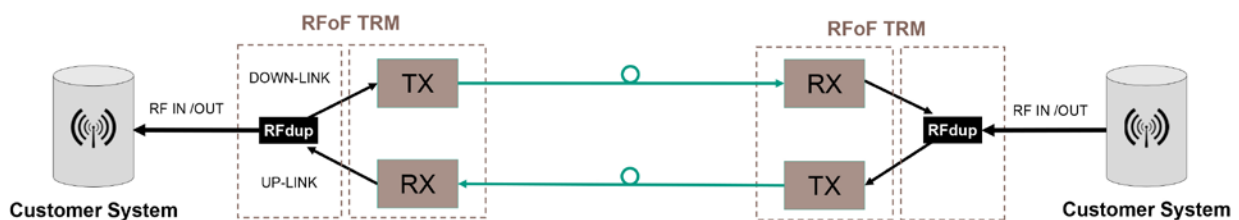

Transceiver module with bi-directional FO functionality

This module incorporates both Transmitter (TX) and Receiver (RX) within the same electronic card, a dual RF connection to the customer system for RF-IN (uplink) and RF-OUT (downlink), and a Wavelength Division Multiplexer (WDM) to transmit and receive the UL/DL signals on two different wavelengths (1310 nm and 1550 nm) within a single fiber.

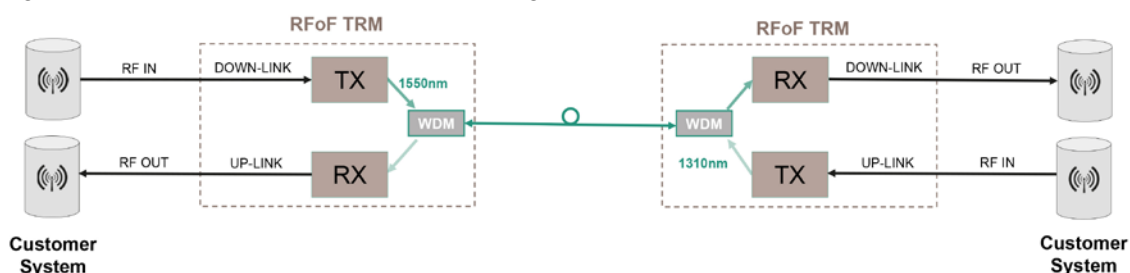

Transceiver module with bi-directional RF & FO functionality

This module incorporates both Transmitter (TX) and Receiver (RX) within the same electronic card, an RF diplexer to separate transmission and reception signals, and a WDM to transmit and receive the UL/DL signals on two different wavelengths (1310 nm and 1550 nm) within a single fiber.

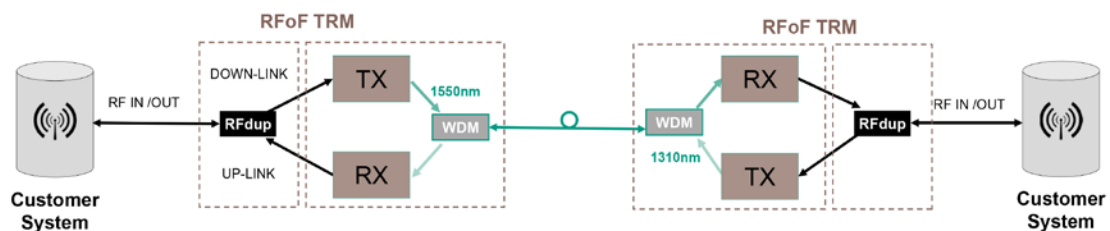

Using intensity modulation of optical laser light by RF signal amplitude ensures that the analogue characteristics of the RF signal are retained from end to end.

The RFoF modules can handle RF frequencies from 1 MHz to 7.1 GHz. Modules with frequency range up to 40 GHz are scheduled for future development.

The RFoF technology is based on Single Mode Fiber (SMF) transmission, which allows high link distances.

The selection of the type of RFoF modules needed and the number of them is dependent on the type of tests required and the number of RF links to be tested by the carrier.

(2) RFoF modules in 19" CUBO rack

The 19" CUBO chassis is utilized to power and manage the RFoF modules. It consists of 9 slots for RFoF module electronic cards and 2 slots for Power Supply Unit (PSU), redundant and supporting both AC and DC.

The Network Interface Controller (NIC) is plugged above the power supplies and supports WebGUI, SNMP as well as RESTCONF interfaces. The 19" CUBO chassis is 3RU high, all module electronic cards are hot swappable and compliant with indoor temperature ranges.

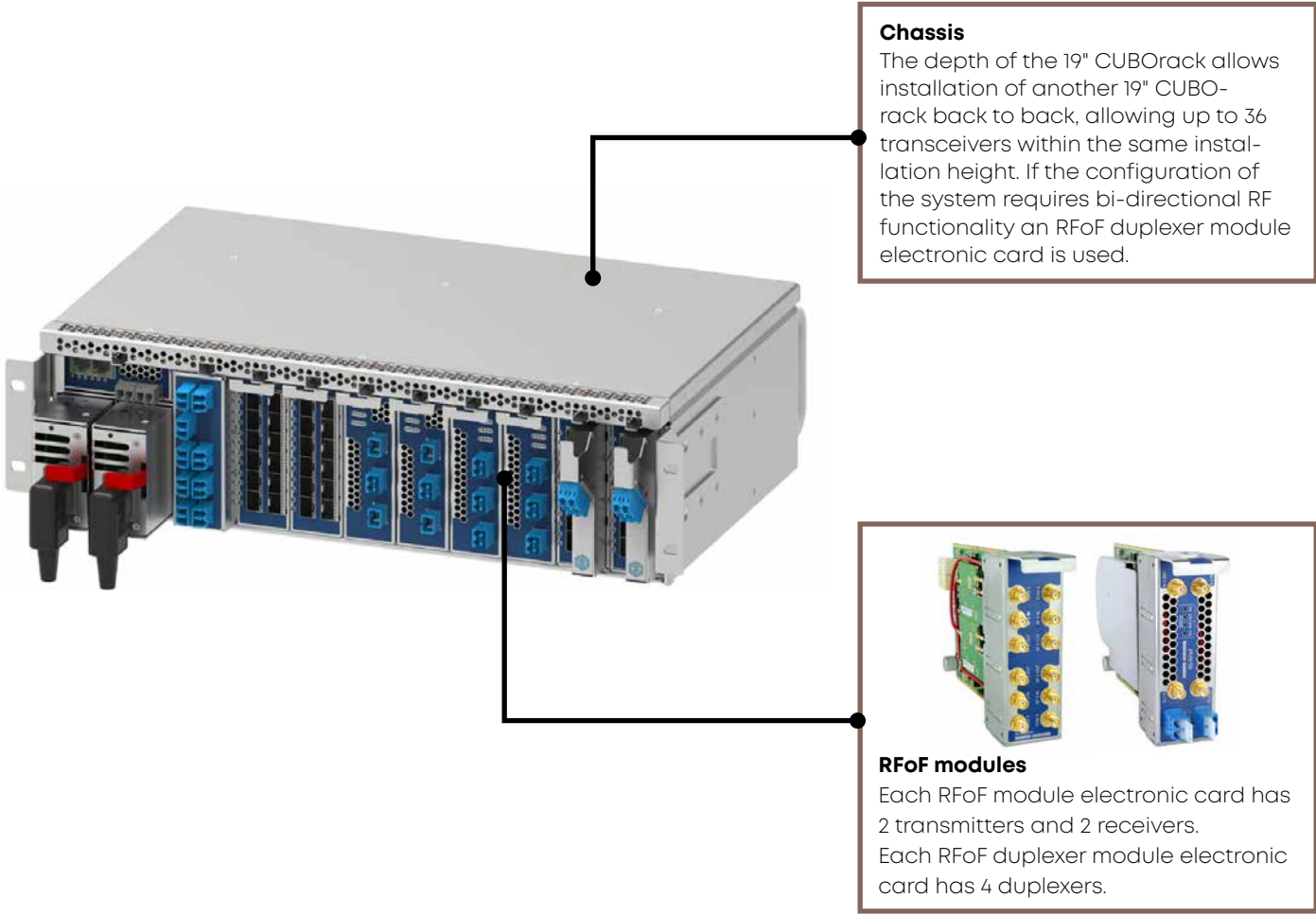

Chassis
The depth of the 19" CUBOrack allows installation of another 19" CUBO-rack back to back, allowing up to 36 transceivers within the same installation height. If the configuration of the system requires bi-directional RF functionality an RFoF duplexer module electronic card is used.

RFoF modules
Each RFoF module electronic card has 2 transmitters and 2 receivers. Each RFoF duplexer module electronic card has 4 duplexers.

(3) POLATIS Optical circuit switch

The optical circuit switch allows the system test resources to be remotely interconnected and easily shared across multiple test topologies in carrier lab environments, without any concern for conflict between different test groups. This enables the provisioning of Lab-as-a-Service (Laas).

The optical circuit switch realizes completely transparent connections without packet processing. This means that tests have a high degree of accuracy.

Additionally the optical circuit switch is transparent to transmission wavelengths, signal direction, protocol and bit rate so the same switch can be used for any media and speed up to 800 Gbps and beyond.

The optical circuit switch can be integrated within test orchestration suites including Quali CloudShell, NETSCOUT® nGeniusONE®, Spirent Velocity® and Spirent iTest®, taking advantage of their ability to store and recall test configurations and topologies enhancing the efficiency of the test setup and process.

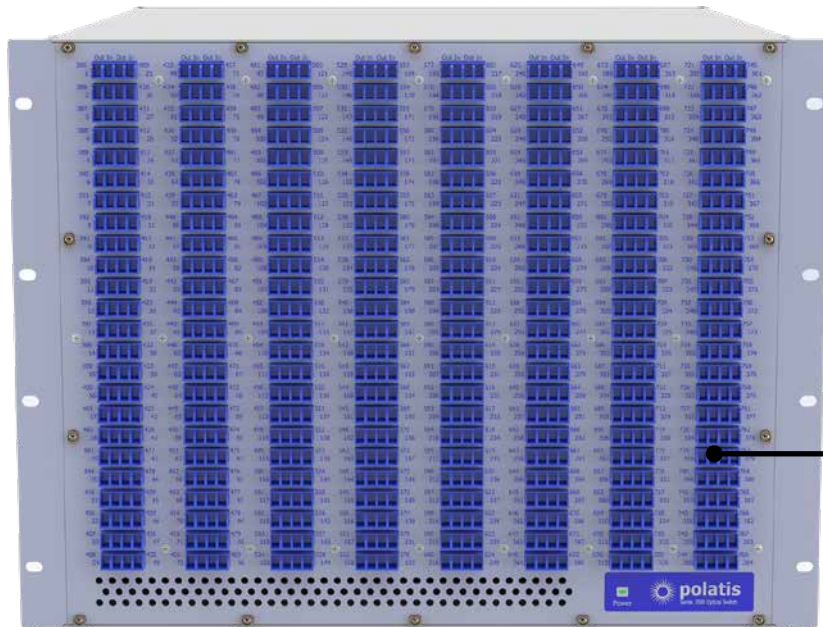

For scenarios where the carriers need only to test digital based interfaces (i.e. CPRI extension testing) or for transport and core labs where there is no need for RF conversion, the Network Management System (5) and (6) API for customer specific software developments can be done through the optical circuit switch without the need of a 19" CUBO rack with RFoF modules.

Various port configurations available from 32 up to 384 ports.

(4) Accessories

HUBER+SUHNER can provide a comprehensive portfolio of RF jumpers as well as FO assemblies and FO cable management solutions suitable for Lab. Automation needs.

(5) Network Management System (NMS)

The CUBO rack is supplied with an Element Management System which displays the status of the 19" CUBOrack and the RFoF modules and allows the user to access them for configuration as well as to perform other management tasks such as general management, slot management and reset functions and reading system status. The WebGUI is a graphical user interface based on a web server.

The SNMP interface is an application-layer protocol which allows the monitoring and managing of the modules through almost any type of umbrella network management system, and is done through the Management Information Base (MIB) available from HUBER+SUHNER.

The POLATIS optical circuit switch is also supplied with a WebGUI which displays the status of the switch and all its cross connections and allows the user to configure the switch settings and make/break cross connections as required.

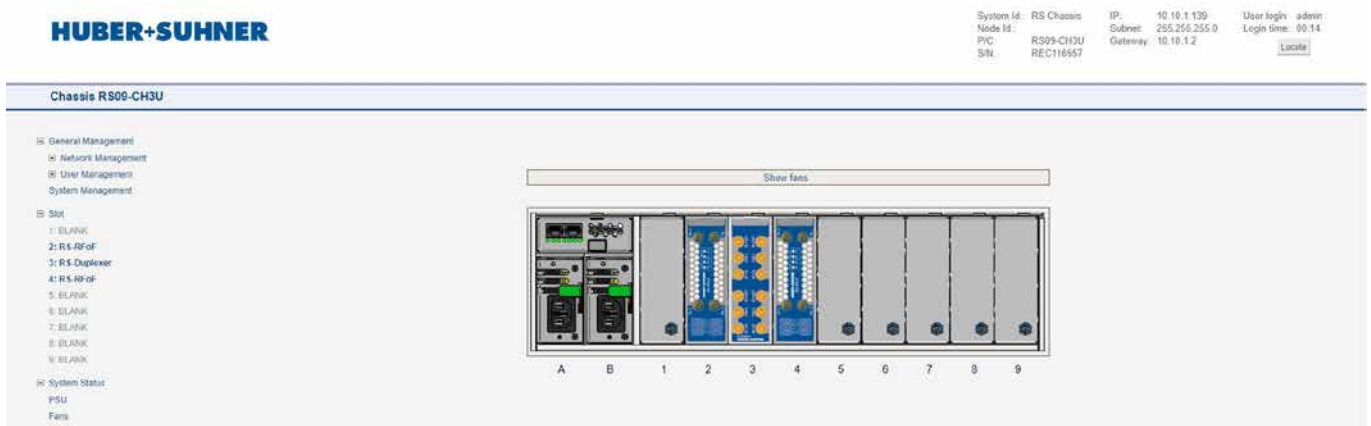
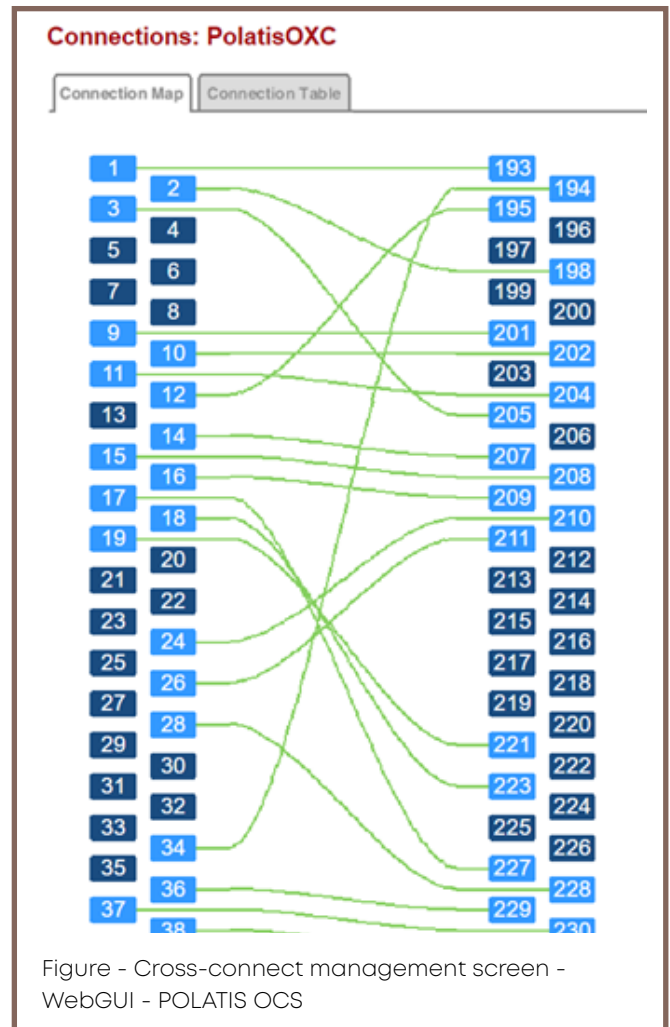

(6) API for customer specific software developments

The customer has a number of options for integrating the CUBO rack with RFoF modules and the POLATIS switch into the wider lab network management system so that automated test routines can be set up.

Both systems come with a variety of APIs, such as RESTCONF, NETCONF, TL1, and SCPI. Customers can use one of those interfaces to integrate them into customized and sophisticated lab automation software, based on scripting and other techniques, to fulfill complex testing needs. RESTCONF uses structured data (XML or JSON) and YANG to provide REST-like APIs, enabling the user to programmatically access different components within the lab architecture.

Through RESTCONF, which is HTTP-based, the user can access data defined in the YANG model. Through YANG data modelling language, the user can model configuration and operational features of the components.

Alternatively there are a number of off-the-shelf lab automation solutions provided by leading vendors in the test and measurement market, some of which have native drivers for the POLATIS switch, RFoF modules or else can use one of the APIs to address and control the systems.

Related documents

Optical circuit switching for network test laboratory automation

[Link \(PDF\)](#)

Further information

RF coaxial cable assemblies

[Harsh environment cabling for the mobile network](#)

Fiber optic management system and fiber optic patch cords

[Structured cabling for data centers](#)

Transceivers

[We make transceivers work](#)

GNSS over Fiber (GNSSoF) for Mobile network operators lab automation time synchronization

[Mobile network connectivity solutions](#)

The HUBER+SUHNER team has extensive experience and knowledge in RF and FO systems actively driving the global evolution of network test lab automation for Carriers. Our best-in-class portfolio is broad and can solve any RF or FO testing challenges.

Contact

European Headquarters

HUBER+SUHNER AG
Degersheimerstrasse 14
9100 Herisau
Switzerland
Phone +41 71 353 41 11
hubersuhner.com