

Splice loss of mass fusion splicing



White Paper

HUBER+SUHNER

Abstract

The splice loss of mass fusion splicing of flexible ribbons was assessed. The insertion loss (IL) of 50 mass fusion splices comprising 600 fibers was measured at wavelengths of 1310 nm and 1550 nm before and after a heat-shrink slim ribbon splice protector was added. The average splice loss was smaller than 0.02 dB for all conditions (1310 nm, 1550 nm, with and without splice protector) and 97 % of the fibers were at 0.04 dB or below. A total of three of the 600 fibers showed a value over 0.2 dB at 1310 nm (max. 0.28 dB), while only 1 fiber at 1550 nm was above 0.2 dB (0.22 dB). The measurement showed that mass fusion splicing with flexible ribbons provides a fast and reproducible method to splice fibers efficiently.

Introduction

Fusion splicing is a common method of joining optical fibers. The fiber ends are brought into close contact and heat is applied to melt the surfaces. The fibers are then pushed together such that the ends fuse together, thereby creating a permanent link with low loss. Especially, single mode fibers with their $9\ \mu\text{m}$ core require precise alignment of the fibers prior splicing. V-shaped grooves commonly are used to align the fibers. The V-grooves must be maintained clean such that there is no contamination that displaces the fiber.

There are three different kinds of fusion splicers available (Figure 1). The simplest splicers just use passive V-grooves for the alignment (V-groove alignment) and can only move the fibers together (x-direction). More sophisticated splicers can align the cladding by moving the V-grooves also in the y- and z-direction (cladding alignment). The best alignment is achieved with core alignment splicers where the cores are illuminated and aligned in the y- and z-direction. Core alignment also takes eccentricity of the core into account.

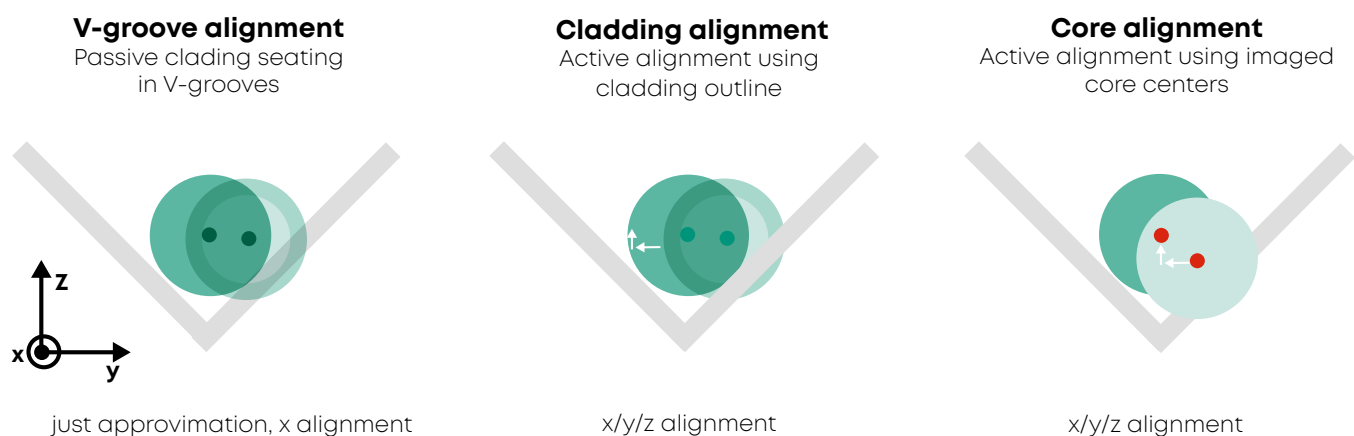

Figure 1: The three different kinds of fusion splicers characterized based on their freedom to align the fibers.

A ribbon fiber is a type of optical cable where multiple individual fibers (typically 12) are arranged side by side. This allows to splice 12 fibers together (so called mass fusion splicing) instead of each individual fiber separately, which greatly reduces the installation time. There are two different ribbon fiber types available, flat ribbons and flexible ribbons. Flat ribbons consist of fibers bonded together over the whole length. This ribbon can only be bent along its longitudinal axis, which requires careful handling during installation and might compromise some of the efficiency benefits gained by fusion splicing. The emergence of flexible ribbons that can be bent in all directions has greatly advanced the use of ribbon fibers. The fibers in flexible ribbons are only bonded at intermittent points along the fibers, allowing for bending in all directions.

However, there are only mass fusion splicers available with passive V-groove alignment, because the holders containing the 12 V grooves do not allow for the individual adjustment in the y- or z-direction. Therefore, the aim of this report was to assess the splice loss of mass fusion splicing and whether applying a heat shrink splice protector increases IL.

Materials and methods

The measurement setup consisted of a 10 m long flexible ribbon connected via a MPO connector to an insertion loss meter (OptoTest OP930), which was equipped with an integrating sphere (OP-SPHR-V2) attached to the power meter as shown in Figure 2. After referencing, the cable was cut, the heat-shrink slim splice protector slid onto one side of the cable and the fibers spliced again. The measured attenuation refers to the attenuation caused by the splicing process. Then, the heat-shrink slim splice protector was shrunk over the splice area and the insertion loss measured again. The difference between the attenuation values can be described as attenuation caused by the shrinkage process. This process was repeated until 50 splices were performed and measured.

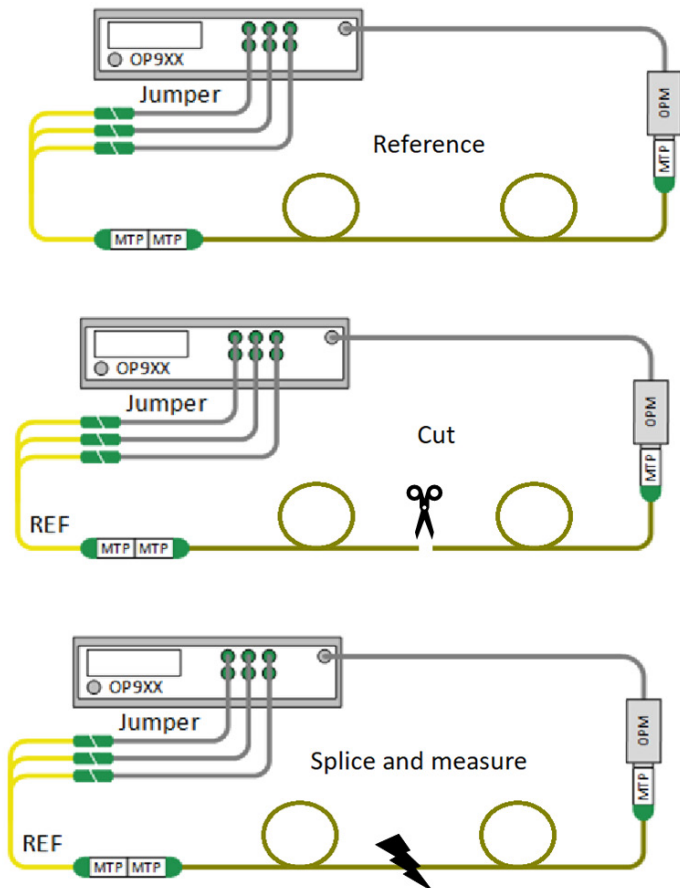

Figure 2: Measurement setup. 10 m of a flexible ribbon cable were connected with MTP to an insertion loss meter. The cable was cut in the middle, spliced and measured, the splice protector was added and the IL measured again.

The flexible ribbon fiber (G.657.A2) used is the one in the OptiRibbon cables (Figure 3). 10 m were terminated on each side with an MPO-APC connector.

The ribbons were spliced with a ribbon fiber fusion splicer (Fitel S124M12 with the fiber holder Fitel S712 12 eL). After the first IL measurements, a slim ribbon splice protector (40 mm length, < 1.6 mm after heat-shrinking) was added over the splice area and heat shrunk for 60 s at 130 °C in the oven of the ribbon fiber fusion splicer. Then, the insertion loss was measured again.

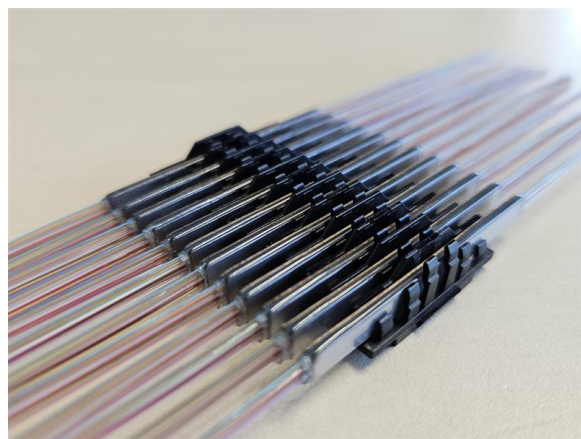
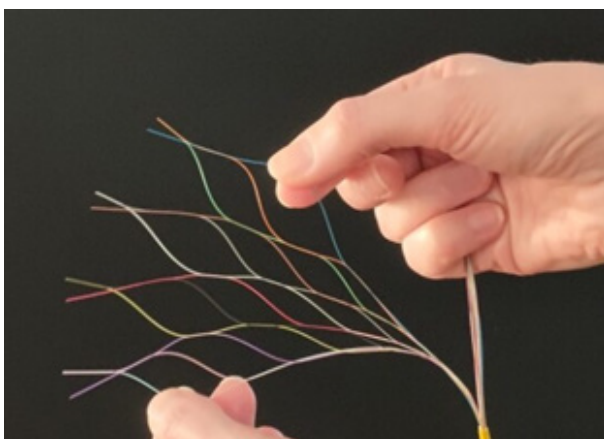

Figure 3: Flexible ribbon design (left) and slim ribbon splice protectors inserted into a splice holder (right)

Results

The insertion loss measurements (IL) for mass fusion splicing of flexible ribbon fibers were conducted at wavelengths of 1310 nm and 1550 nm, both with and without a splice protector (Table 1). The average splice loss was smaller than 0.02 dB for all conditions (1310 nm, 1550 nm, with and without splice protector) and 97 % of the fibers were at 0.04 dB or below.

Table 1: Insertion loss measured at 1310 nm and 1550 nm, first without (w/o) splice protector, and then with the splice protector added (w).

Wavelength	IL 1310 nm		IL 1550 nm	
	w/o	w	w/o	w
Splice protector	w/o	w	w/o	w
Mean [dB]	0.02	0.02	0.02	0.02
≤ 0.04 dB	98.3 %	98.2 %	97.8 %	98.0 %

The scatter plots in Figure 4 show the distribution of IL measurements for 50 ribbon splices (600 fibers) at both wavelengths, with and without a splice protector. The heat-shrinking of the splice protector over the spliced ribbon did not increase the insertion loss (each value with splice protector minus the value without splice protector: Average -0.0002 and -0.0003 dB at 1310 and 1550 nm, respectively).

Two ribbons showed elevated IL values for some fibers. In ribbon number 6, the 1st and 2nd fibers were affected (0.19/0.18 dB and 0.28/0.28 dB at 1310 nm; 0.14/0.14 dB and 0.22/0.22 dB at 1550 nm with/without splice protector, respectively). In ribbon number 30, the 6th and 7th fibers were affected (0.25/0.26 dB and 0.21/0.21 dB at 1310 nm; 0.17/0.17 dB and 0.16/0.15 dB at 1550 nm with/without splice protector, respectively). Of the 600 spliced fibers, the IL of three splices was above 0.2 dB when measured at 1310 nm and only one value of 600 was above 0.2 dB when measured at 1550 nm.

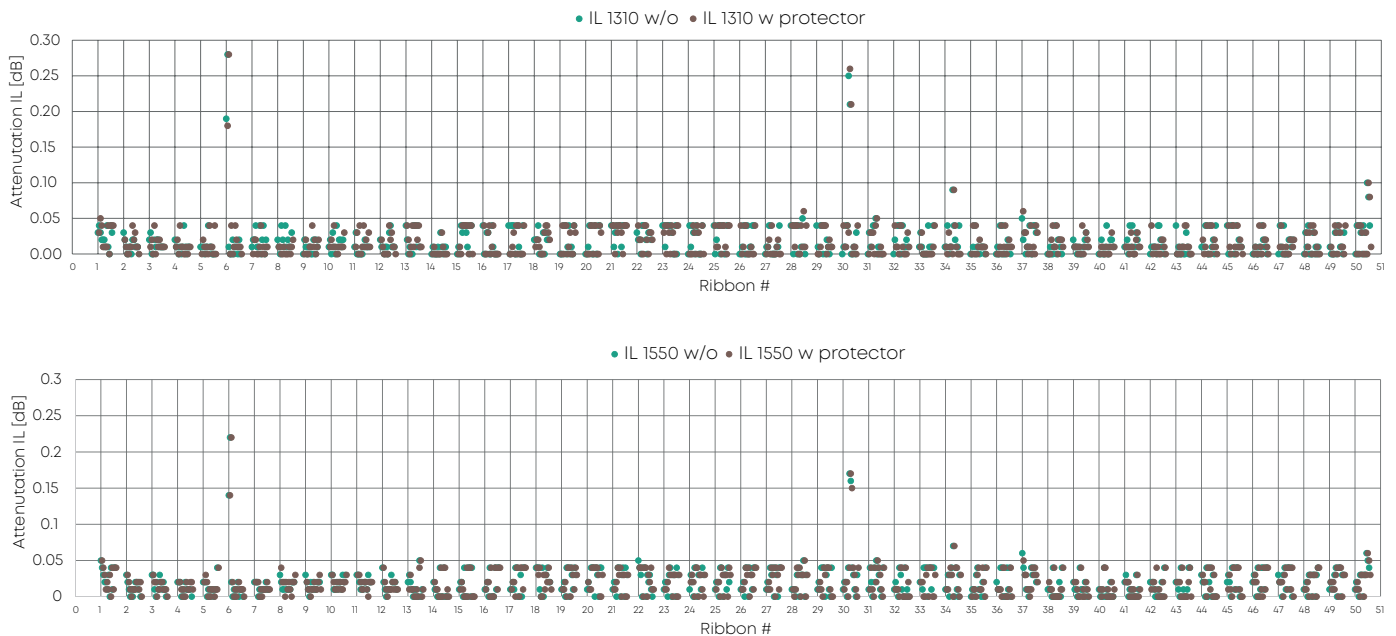

Figure 4: Scatter plot of the insertion loss of the 50 ribbons (600 measurements each) without (w/o, green) and with (w, brown) protector measured at 1310 nm (upper panel) and 1550 nm (lower panel), respectively.

Conclusions

The measured insertion loss (IL) of all 600 fibers (50 ribbons) was in average 0.02 dB and 97 % were at 0.04 dB or below. The low average and 97% IL values show that a low splice loss can be achieved with passive V-groove alignment when performing ribbon mass fusion splicing. It further showed that protecting the splice with our slim splice protectors (< 1.6 mm after heat shrinking) does not increase the insertion loss.

ITU-T L.400/L.12 specifies that for the validation of splicing procedures of single-mode fiber splices, there should be made 100 splices on the same optical ribbon. In our test, we used the same optical ribbon but performed only 50 instead of 100 splices, which gives our data a lower statistical power. ITU-T L.400/L.12 defines for ribbon fibers with passive alignment by V-grooves a loss of ≤ 0.1 dB in average and ≤ 0.2 dB in 97 % of the splices. Our measured values are 5 times lower than these specified limit values.

It is noteworthy that from the 50 ribbons, in 2 ribbons each 2 adjacent fibers showed elevated IL values. It could be speculated that it stems from the design of the flexible ribbon (see Figure 3). If the stripping of the ribbon starts just past a connection point, there might be a certain stress on the fibers that results in the fibers not coming straight into the V-grooves and thereby not being in the perfectly aligned position for the splicing. However, with only two incidents, there is not enough evidence available to draw a conclusion.

The fusion splicer also estimates the splice loss during splicing. However, it did not detect the elevated values (Table 2). This means that a bad splice is only detected after the system is installed and the installer probably already left. In case a splice needs resplicing, the whole ribbon must be respliced.

Table 2. Pictures (from two angles X and Y) and estimated IL from the splice machine compared to the highest measured values. From the pictures, no misalignment can be deduced, which is also reflected in the estimated IL from the machine.

Ribbon	Image X	Image Y	Insertion Loss			
			Fiber	Estimated IL	Measured IL	
No. 6					1310 nm	1550 nm
			1	0.02 dB	0.19 dB	0.14 dB
			2	0.01 dB	0.28 dB	0.22 dB
No. 30			Insertion Loss			
					1310 nm	1550 nm
			6	0.01 dB	0.25 dB	0.17 dB
			7	0.01 dB	0.21 dB	0.16 dB

Even though the 97 % IL value is far below the specified 0.2 dB, 3 fibers at 1310 nm and 1 at 1550 nm were above 0.2 dB. The highest observed value was 0.28 dB. A common value for a splice loss used in the calculation of the loss budget of a network is 0.1 dB. However, it also means that the required power budget is overestimated as the average splice loss is much smaller. In a connection with several splices - one with the maximum loss (0.28 dB) and the rest with average losses (0.02 dB) - the mean loss would be for 2 splices 0.15 dB, for 3 splices 0.11 dB and for 4 splices 0.09 dB, respectively. It is likely that the splice with the highest IL will not require re-splicing, even when accounting for 0.1 dB/splice in the loss budget, because a single increased loss can be neglected over the entire channel (from transceiver to transceiver, including connector, cable, bending and splice losses plus margin).

The measurement showed that mass fusion splicing with flexible ribbons provides a fast and reproducible method to splice fibers efficiently with low loss. In addition, the protection of the splice with our slim splice protectors did not increase the insertion loss.

Author: Lukas Pfister / FO R&D
Review: Jonas Hanimann / FO Test Lab

Disclaimer: The results presented in this report are based on laboratory tests conducted at HUBER+SUHNER and are intended to demonstrate the potential of the technology under controlled conditions. Actual performance may vary in field applications, especially when working under time constraints or suboptimal conditions. Splicing different types of fibers may also result in higher insertion loss than reported here.

HUBER+SUHNER AG
Degersheimerstrasse 14
9100 Herisau
Switzerland
Phone +41 71 353 41 11
hubersuhner.com

HUBER+SUHNER is certified according to ISO 9001, ISO 14001, OHSAS 18001, EN(AS) 9100, IATF 16949 and ISO/TS 22163 – IRIS.

Waiver

Fact and figures herein are for information only and do not represent any warranty of any kind.